



QUICK START UP GUIDE for WELDER Model

L/45



OPEN PACKAGE AND PLACE ALL ITEMS ON A WORKING BENCH TABLE.

The package contains: burner tips; user manual; quick start guide; DVD guide; USB tutorial guide; spare fuse; plastic funnel; torch(es); fire proof plastic hose; power cord.

For a better understanding, Elettronica Todescato recommends to take vision of our DVD and/or USB Key guide, and to simultaneously consult the present manual.

Step 1 Make sure that the switch is turn on “O” (OFF). Then, plug the power cord / cable into the machine and into the electrical outlet making sure the voltage is correct.



(3 POSITION SWITCH)

Step 2 PREPARE THE ELECTROLYTE SOLUTION

Carefully read **Section 4.2** in the **USER MANUAL** and follow the instructions properly to prepare the electrolyte solution. Make sure to understand the necessary pre-cautionary procedures explained under the “DANGER”  symbol, in **section 4.2** in the **USER MANUAL** to avoid hazardous complications and mistakes.



ATTENTION!

Always use clean objects to prepare the electrolyte solution. If some of the tools used are not clean wash then with tap water a few times until day are clean and after dry then with a rag.

DO NOT USE DETERGENTS OR LIQUID SOAPS.

ATTENTION!

It is important to use protective gloves and glasses due to the corrosive nature of the solution.

- NOTE:**
- $\frac{1}{2}$ liter of distilled or demineralized water needed to fill the tank.
 - Mix with **180 grams of KOH** (Potassium Hydroxide).
 - Let the chemical components cool down for 10 to 15 minutes or more.
 - **In appendix 1, there are Conversion Tables that can assist you in the amounts needed for different units of measure.**

Step 3 UNSCREW THE SAFETY CAP ON TOP OF THE MACHINE.



(SAFETY CAP)

Step 4

Turn the switch into the down position (“=”) to refill, this will enable the operator to check the level of demineralized water.



(3 POSITION SWITCH)

Notice:

- a.** Green light is “on”, indicating the machine is connected to the electricity. (pic 1)
- b.** Yellow light is “on”, initially indicating the internal tank level is empty and needs to be filled, or the water level is below normal during daily usage and there is need to add more water. (see picture below)
- c.** Red light is, “off”, indicating that the internal tank needs to be filled.

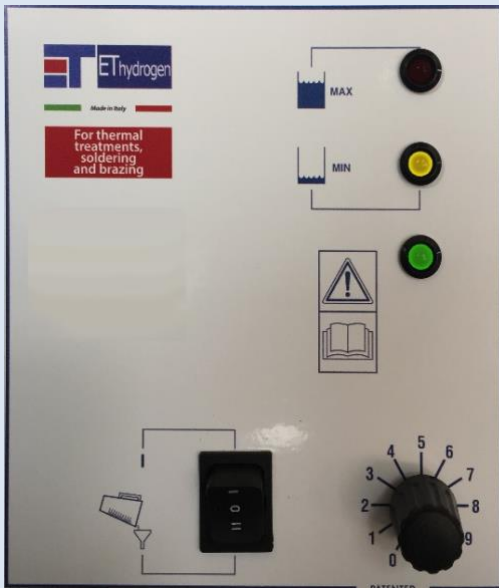

(picture # 1)

Step 5 POUR ELECTROLYTE SOLUTION

IMPORTANT NOTICE:

The electrolyte solution's lifetime is of one year.
It must be poured when:

- 1- Using unit for the first time.
- 2- When solution has previously been poured through contaminated or dirty funnel.
- 3- When unnecessary or contaminated liquids have been poured inside the internal tank, such as deoxidizer, etc.

After the electrolyte solution has cooled off, pour the solution into the internal tank (slowly) using a funnel, until the Red-light indicator comes on, (pic. 2) indicating the internal tank is properly filled. At the same time, the Yellow light will turn "off", indicating that the tank is being filled and has reached above the minimum level required. Stop pouring the solution, as soon as the red light comes on.

When the red light comes on, stop pouring the demineralized water, in order to avoid over filling the tank.

(This is IMPORTANT: DO NOT OVERFILL). Then close the cap tightly safe.

Notice: The booster tank initially is disconnected.



(picture #2)

Step 6 PREPARE THE DEOXIDIZER

FLUX (deoxidizer) Methyl Alcohol (1 liter) + Boric Acid (15 – 20 grams)

sec . 4.5 in the USER MANUAL,

contains the procedure and safety precautions to follow.



*EXAMPLE OF
HERMETIC SEAL*

Step 7 BOOSTER TANK FILLING

Take the un-attached booster tank in hand, start pouring the deoxidizer in the booster tank by placing your index on the hole in the center of the booster tank to avoid filling the interior chamber.



Fill to the max level indicated on the outside of the booster tank. **(DO NOT OVER-FILL)**

STEP 8.

BOOSTER TANK INSTALLATION

To mount the booster tank after having it filled with the flux (deoxidized), tighten the handle knob making sure to not over screwing in order to preserve the gaskets and the internal thread of the booster tank.



(BOOSTER TANK HANDLE KNOB)

NOTE : For daily use and refill, refer to the section called “ **ATTENTION ! (page 10).** “

Step 9.

UNSCREW THE THREADED NUT REFERENCE

(Fig. 5 # 17) in the User Manual.



Insert the plastic hose into the fitting, making sure you tighten the ferrule for a proper connection.

STEP 10

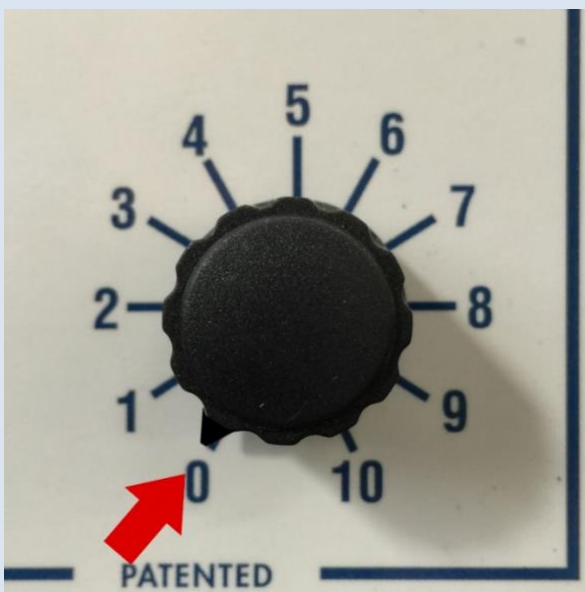

IMPORTANT: Before turning on the machine set the power control knob to zero.



STEP 11.

After mounting the booster tank, begin by selecting the green burner tip (largest one).

Refer to **TABLE 2**, below.

NUMBER OF TORCHES	BURNER TIP EXTERNAL DIAMETER			POWER ADJUSTMENTS	
				Min	Max
1	Ø 0.6 mm/0.0236 inch		VIOLET	1	8
1	Ø 0.7 mm/0.0275 inch		BLACK	3	9
1	Ø 0.8 mm/0.0314 inch		GREEN	6	10

STEP 12.

Switch the machine on by turning the switch up into “-”.

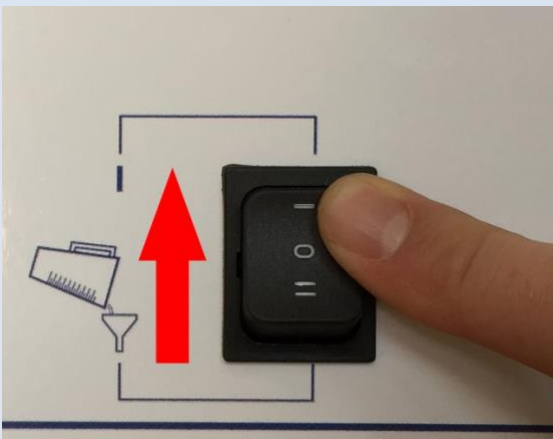

(3 POSITION SWITCH)

After turning the machine on, a couple of minutes later, gas production will start. Wait until you hear the gas being discharged and flow easily from the burner tip.

STEP 13.

Then check and adjust the minimum / maximum settings for the power control knob **(picture A)** according to the diameter of the burner tip. **(See table 2).**

Failing to follow the suggested min/max settings will result in melted or fused burner tips.

Take the selected burner tip and push it in place at the end of the torch **(picture B).**

NOTE: Make sure the power control knob is in the proper position BEFORE lighting the flame.

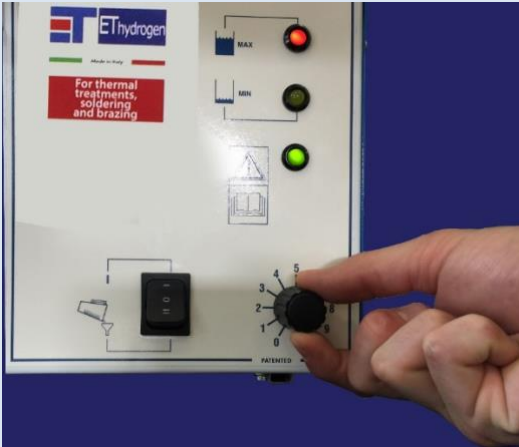

(picture A)

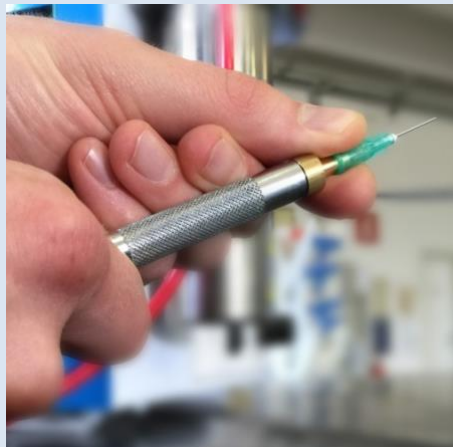

(picture B)

STEP 14.

Wait to the gas to exit from the burner tip (approximately two/three minutes or more), then light the flame with a lighter or electronic igniter.

If the flame is too weak move on to the next burner tip on table two (2).



(TORCH AND FLAME)

STEP 15.

To turn off the machine switch the flame off by pushing the base of the torch (as you do with a pen), then ultimate the procedure by turning the switch to "0".

Always shut the flame **OFF**, before turning machine off.

Do not turn the machine "off" while the flame is lit.

Always, turn **OFF** the flame from the torch, before shutting down the machine, always.

See picture below.

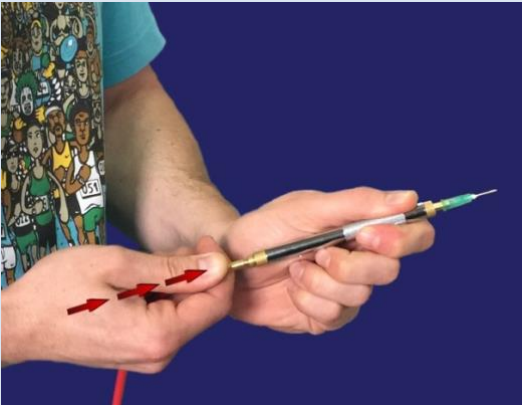

IMPORTANT NOTE:

For the first startup of our ET systems, or for the yearly maintenance (once every year), the machine must be filled or re-filled with electrolyte solution.

For the daily re-fill it is mandatory to pour only demineralized (or distilled) water inside the electrolyte tank.

Pouring daily electrolyte solution will cause a crystallization inside the tank and consequent obstructions of machine's hoses, potentially causing a general malfunction.

**GOOD DAILY HABITS FOR MAINTAINING THE MACHINE
AT OPTIMAL PERFORMANCE**

A T T E N T I O N

1. Do not unscrew the “booster tank” nor the “safety cap”, while the flame is on.
2. Do not leave the machine on for more than 30 minutes, while the flame is “off”.
3. **Refill the internal tank with WATER by depressurizing the booster tank first.**

Whenever water or electrolyte solution need to be added to the internal tank it is **IMPORTANT** to depressurize the booster tank first by simply unscrewing the handle-knob (see photo in Step # 8). This will prevent the flux (deoxidizer) from contaminating the electrolyte solution.

A) unscrew safety cap and add water or electrolyte solution until the Red light comes on, indicating it’s full.

B) afterwards retighten the safety cap and the booster handle knob. Taking care not to over tighten, nor over-screw, no break the internal chamber’s thread.

This will become a daily, standard operation, as water will be constantly added to the internal tank, before starting the working day.

4. Do not turn the machine off while the flame is lit. Always, turn **off** the flame from the torch, before shutting down the machine. Always do this as a pre-cautionary procedure.
5. Shut **off** the flame before refilling any liquid flux deoxidizer or demineralized water
With the tanks full, the machine will operate approximately 6-8 hours.
6. If only the booster tank needs refilling, DO NOT OPEN THE SAFETY CAP on top of the machine. Just remove the booster tank and fill accordingly to the max level placing the index in the center to avoid spilling fluid in the hole in the center of the tank. Reattach the booster tank when done filling.
7. If both tanks need re-filling, first depressurize the booster tank by removing it, then remove the Safety Cap on top of the machine. Then pour water in the Internal Tank until the Red light comes on (indicating it’s filled). Screw safety-cap back on top, then add the flux (deoxidizer) to the booster tank and tighten.
8. Whenever the machine has been refilled, it must be pressurized. Do not refill and let sit overnight without turning on to pressurize.

9. When turning the three-position switch to the down position, (fill-refill “=”), you will be able to check level of the demineralized water located in the internal tank.
 - a. If the Red light is **off**, then water is needed in the internal tank, fill until the red light comes, “on”.
 - b. If the yellow light indicator is “on”, then it’s below the acceptable usage level and water must be added.
 - c. If both the (Red & Yellow) lights are off, then the water level is somewhere in the middle of the tank.

10. If the machine is not used for 15 - 20 days, turn **ON** the welder for at least 3 minutes to max power **without** lighting the flame, to avoid that the check valve does not become blocked. After that, turn, **OFF** the machine.

DO NOT DEPRESSURIZE THE INTERNAL TANK BY UNSCREWING THE SAFETY CAP.

11. Do not let gas out of the torch for more than fifteen (15) to twenty (20) minutes without lighting the flame (the exit of gas only isn’t good for the environment).

12. Do not light the flame until the gas flows out from the burner tip and at the same time the Power Control Knob MUST be in the correct position according to Table 2 (see user manual and/or the sticker positioned on top of the cover machine – Fig.5 # 32, in the user manual) settings, before lighting the flame.

13. Clean the orifice (Fig. 1 # 11) with a thin steal wire or other similar safe object, in order to avoid causing personal harm or damage to the burner tip. You can also clean the burner tip in lukewarm water for approximately twenty minutes.

APPENDIX 1

INFORMATION ON CHEMICALS USED IN OUR HYDROGEN GENERATORS.

- **ELECTROLYTE SOLUTION (LIQUID):**
GO TO STEP 2 IN THE QUICK START GUIDE.

Electrolytic solution ready for use

COUNTRY	WELDER MODEL	QUANTITY OF ELECTROLYTE (LIQUID)
EU	L/45	EU LT 0.5
USA	L/45	US gal 0.133
UK	L/45	UK gal 0.109

- **ELECTROLYTE SOLUTION IN DRY BAG:**
GO TO STEP 2 IN THE QUICK START GUIDE.

How to prepare the electrolytic solution with dry bag.

COUNTRY	WELDER MODEL	QUANTITY OF DEMINERALIZED WATER	QUANTITY OF POTASSIUM HYDROXIDE (KOH in FLAKES or POWDER with 90% of PURITY)
EU	L/45	LT 0,445	grams 180
USA	L/45	US gal 0,118	ounces 6.35
UK	L/45	UK gal 0,098	ounces 6.35

- **FLUX (DEOXIDIZER) COMPOSITION:**
GO TO SECTION 4.5 IN THE USER MANUAL.

A liquid with particular compounds in order to obtain a clean flow solder. Useful for avoiding oxidation and porosity during the soldering / brazing process.

FLUX (DEOXIDIZER) STANDARD COMPOSITION (EU UNIT OF MEASURE)	1 Lt of Methyl Alcohol + (15 to 20) grams of Boric Acid
FLUX (DEOXIDIZER) STANDARD COMPOSITION (USA UNIT OF MEASURE)	US gal 0.264 of Methyl Alcohol + (0.529 to 0.705) ounces of Boric Acid
FLUX (DEOXIDIZER) STANDARD COMPOSITION (UK UNIT OF MEASURE)	UK gal 0.219 of Methyl Alcohol + (0.529 to 0.705) ounces of Boric Acid

DANGER

! ATTENTION!



DO NOT TURN/UNSCREW THE SAFETY CAP AND/OR THE HANDLE WHILE THE FLAME/FLAMES IS/ARE LIT



NEVER LEAVE THE MACHINE **ON** WITH THE TORCH SWITCH **OFF**.
AVOID GAS DISPERSION IN THE ENVIROMENT.



DO NOT TURN THE MACHINE **OFF** WHEN THE FLAMES ARE **LIT**.



DO NOT PLACE THE FLAME NEAR THE MACHINE, IN PARTICULAR, ON THE BOOSTER TANK, SAFETY CAP, THE FILLING NECK, THE BOOSTER HANDLE KNOB OR THE GAS HOSES.

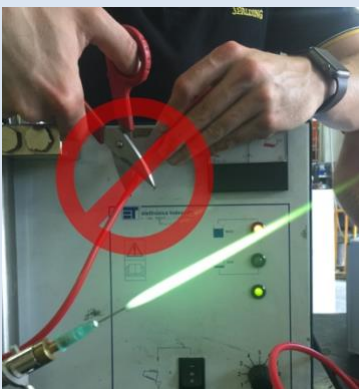

DO NOT CUT THE GAS HOSES WHILE FLAMES ARE LIT.

ATTENTION: the flame reaches a very high temperature of (3200°C / 6100°F).

DO NOT COME IN CONTACT WITHIN THE VICINITY OF THE FLAME, (WITH A MINIMUM OF 50 CM / 20 INCHES). THE FLAME IS VERY DANGEROUS, AND MAY CAUSE, SEVERE ENJURIES IF THE OPERATOR DOES NOT FOLLOW THESE RULES.

KEEP THE MACHINE AND ITS ATTACHED AND UNATTACHED ACCESSORIES AWAY FROM CHILDREN.

Do not allow gas to enter the environment for more than 15-20 minutes.
Alternatively, it is best to turn off the machine completely.

ATTENTION!

ONCE A YEAR

For optimal performance of equipment, a yearly maintenance is required, with instruction located in sec. 5.3 of the technical user manual.



Via Alessandro Volta 9/A, 36057 Arcugnano, (VI), ITALY
-Tel: +39 0444 289227 - fax: +39 0444 289229 -
info@elettronicatodescato.com - www.elettronicatodescato.com