

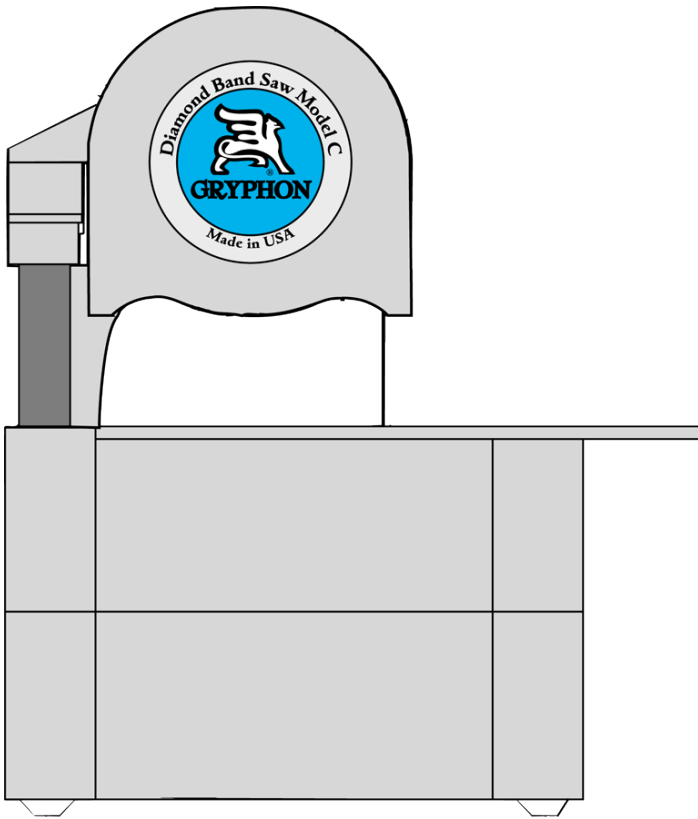

Sharing your passion for making jewelry.  
Products. Service. Know-how.

# Gryphon Diamond Band Saw Instructions

Model C-40



## Safety Precautions

- Always wear eye protection
- Do not run blade dry
- Keep fingers clear of moving parts
- Lift off motor when cleaning

## Warranty

Your new Gryphon Diamond Band Saw is warranted for one year from date of purchase. All mechanical parts with the exception of the blade, blade guide and sponge are guaranteed against failure for one year. If such a failure occurs for any reason other than abuse or misuse during this period, it will be repaired or replaced (at manufacturer's option) free of charge FOB our factory. Retain your sales receipt for proof of purchase. Should repairs ever be required, contact Rio Grande at 505-545-6566 or at info@riogrande.com.

## Index

Warranty .....	1	Sponge and Water Installation .....	5
Safety Precautions .....	1	platform & cover Installation .....	5
Exploded View .....	2	Marking your Pattern .....	5
User Precautions .....	3	Cutting Glass .....	5
Unpacking .....	3	Cutting Other Materials .....	6
Assembly .....	3	Cleaning the Saw .....	6
blade Installation .....	4	Replacing lower wheel adjustment screw.....	6
Trial Run and blade Adjustment .....	4	Replacing lower wheel Bushing .....	7
Lower guide Installation .....	4	Replacement Parts .....	7
Upper guide Installation .....	4		

# Exploded View

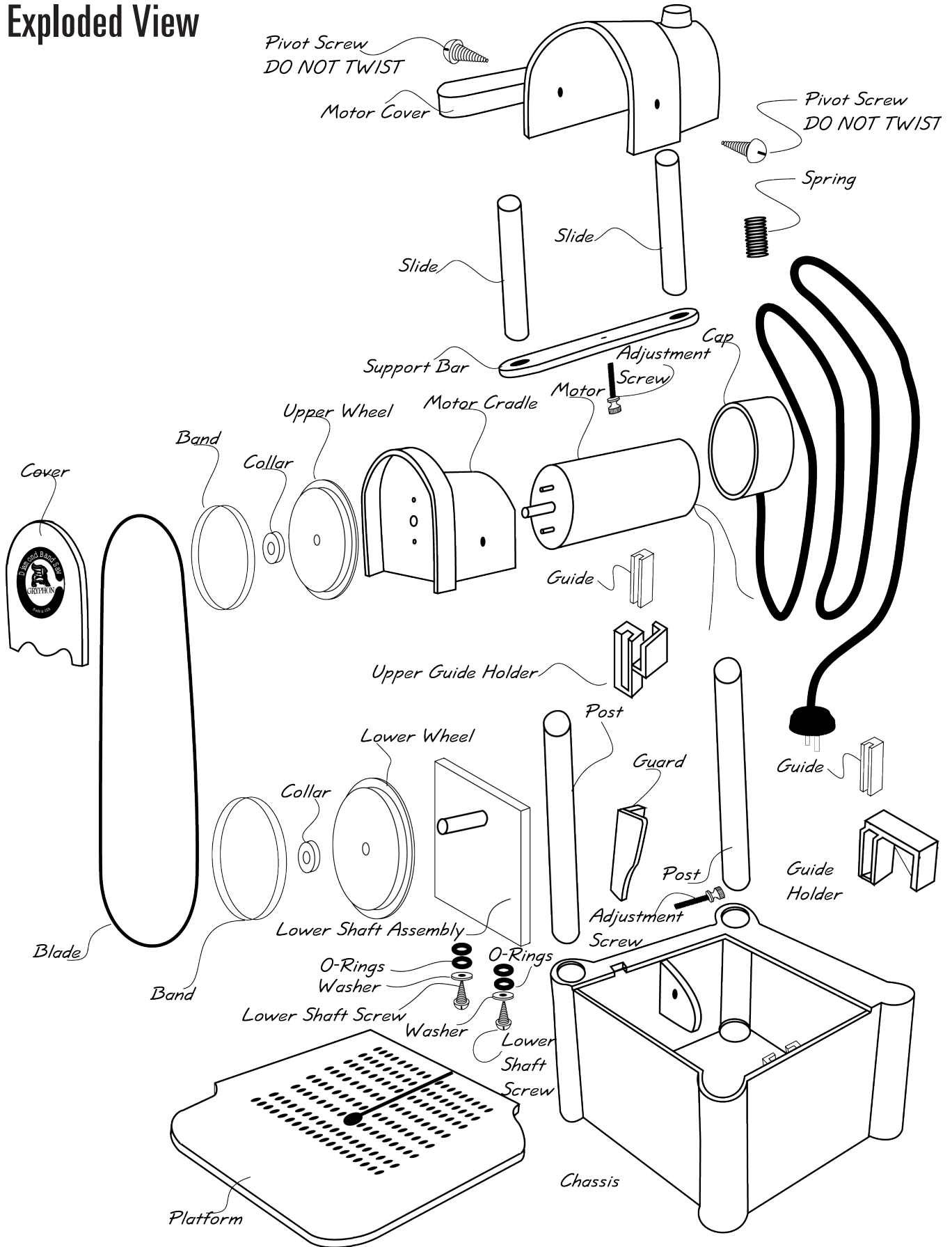

Congratulations on purchasing the world's fastest diamond band saw. The cutting speed approaches, but just stays under, the speed at which glass glows under water during cutting.

## User Precautions

- Keep your fingers away from the moving blade—**blade rotates at 40 miles per hour.**
- Keep the water level near the top of the sponge in the water tray (see page 6). As this sponge wears, the amount of cooling water delivered to your glass is reduced, and glass damage will occur. If the glass you are cutting appears dry, change the sponge. Sponges should be ½" thick.
- Do not bend or kink your blade. Heavy saw vibrations result from running bent blades.
- Use only Gryphon #301 blades on this high-speed saw. blades from other manufacturers cannot withstand the 40mph blade speed. Other blades usually cause vibration and run at a high noise level and, after 2 to 4 hours of running time, are prone to breakage.
- Your saw warranty is separate from your blade warranty. See the blade box for blade warranty.
- This a high-speed tool. It is essential that you read all instructions and follow all safety recommendations.

## Unpacking

Your shipping carton contains the following parts:

- Instructions
- Top assembly
- Bottom assembly with guide holder installed
- platform
- blade (coiled in box)
- upper blade guide holder
- Three guides
- Two sponges
- Spare lower adjustment screw and two nuts\*

\* **IMPORTANT! Do not** turn either of the adjustment screws on your saw. These are preset for your blade at the factory. The use of these spare adjustment screws is addressed later in this booklet.

## Assembly

Assembly is very simple. Refer to the drawing on this page to:

- Remove tape used in packing.
- Insert slides on top assembly into posts on bottom assembly as shown.
- Push top assembly down as far as it will go (note that the adjustment screw controls how far down the top assembly will go). Do not turn the upper adjustment screw yet.
- Remove cover by sliding it straight up.

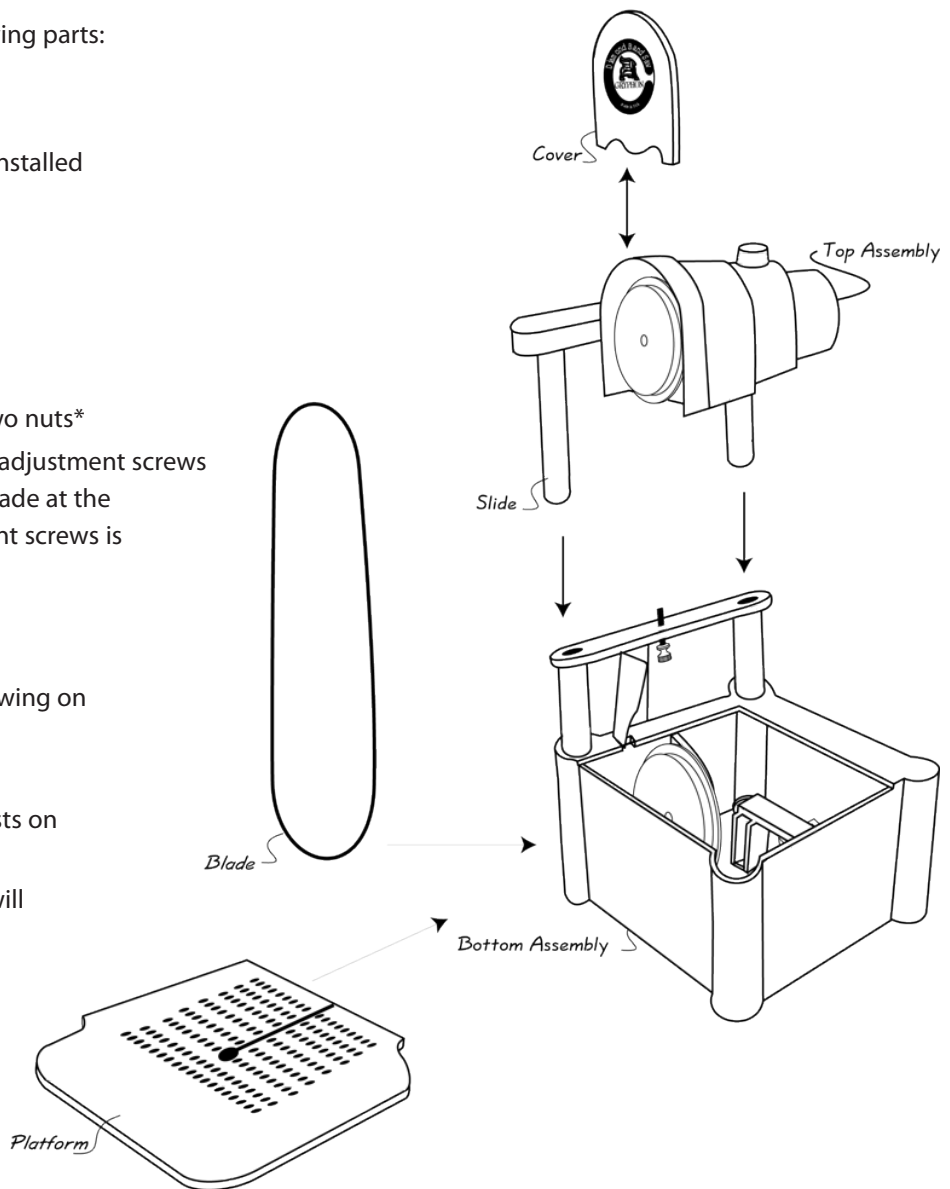

## Blade Installation

- Remove coiled blade from box.
- Uncoil the blade gently. Do not bend or kink the blade.
- Place blade under lower wheel with diamond side toward the front of the saw.
- Place blade at 9 o'clock position on upper wheel and rotate upper wheel by hand clockwise to wrap the blade over the upper wheel. blade should pass through slot in guide.
- Turn the upper wheel by hand until the blade walks to the back of the upper wheel.

## Trial Run & Blade Adjustment

- Route power cord through the slot provided in top assembly and plug into a standard grounded outlet. The upper adjustment screw is factory-set. Use the following steps to make your own adjustment.
- While pressing down gently on the back of the motor (to keep tension on the blade), flip the on/off switch to the "on" position.
- By tightening the adjustment screw, you raise the motor back and bring the blade toward the front of the upper wheel. Loosening this screw will bring the blade toward the back of the upper wheel.
- Tighten the adjustment screw until the blade has minimum wobble but stays in the guides. If the saw becomes louder and vibrates, loosen the adjustment screw until the saw quiets down.
- You will not need to adjust the lower adjustment screw. This control for the tilt of the lower wheel is set at the factory and should not require further attention.
- Turn the saw off.

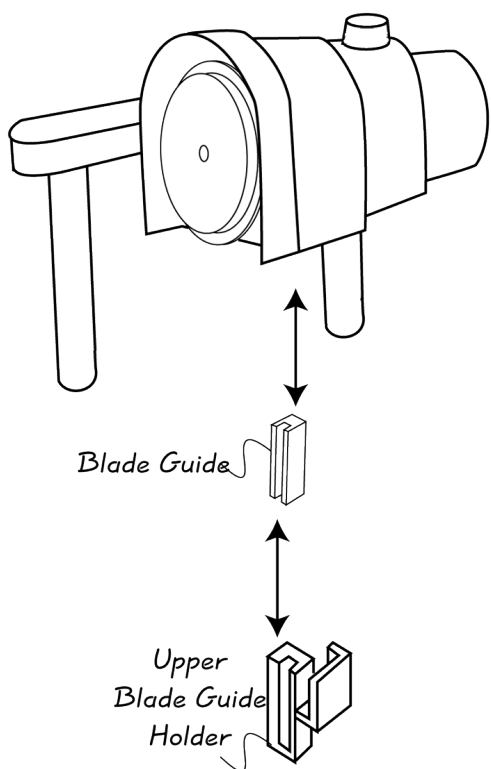
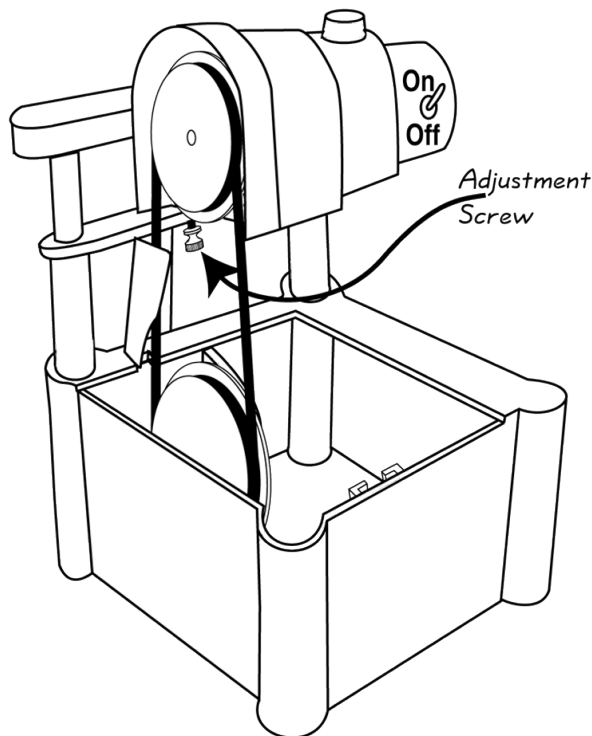

## Lower Guide Installation

- Your saw was shipped with the guide holder in place. If it has become loose or fallen out in shipment, reinsert it into slot on inside wall of chassis. Push firmly into place so that top of guide holder is flush with top of chassis.
- Slide one guide into slot on guide holder (the slot on the guide must face outward).
- Blade fits in slot of guide.

## Upper Guide Installation

- Install a guide into the upper blade guide holder in the same way as you installed the guide into the Lower guide holder.
- Install the upper blade guide holder onto your band saw by inserting it over the rear right-hand corner of the motor Cradle as shown.
- The upper blade guide holder may be removed or reinstalled at any time.

## Sponge and Water Installation

- The sponges reduce the water splash.
- Wet both sponges.
- Insert sponges in locations shown in cutaway drawing at right. Ridges are molded into the saw to keep the sponges in place.
- Pour water into chassis. Water level should not be higher than the top of the bottom sponge. The use a corrosion inhibitor or other additive in the water recommended as it will not benefit the function of saw.
- Rotate or replace sponges when worn.
- Additional sponges can be cut from a standard kitchen sponge available at your grocery store.

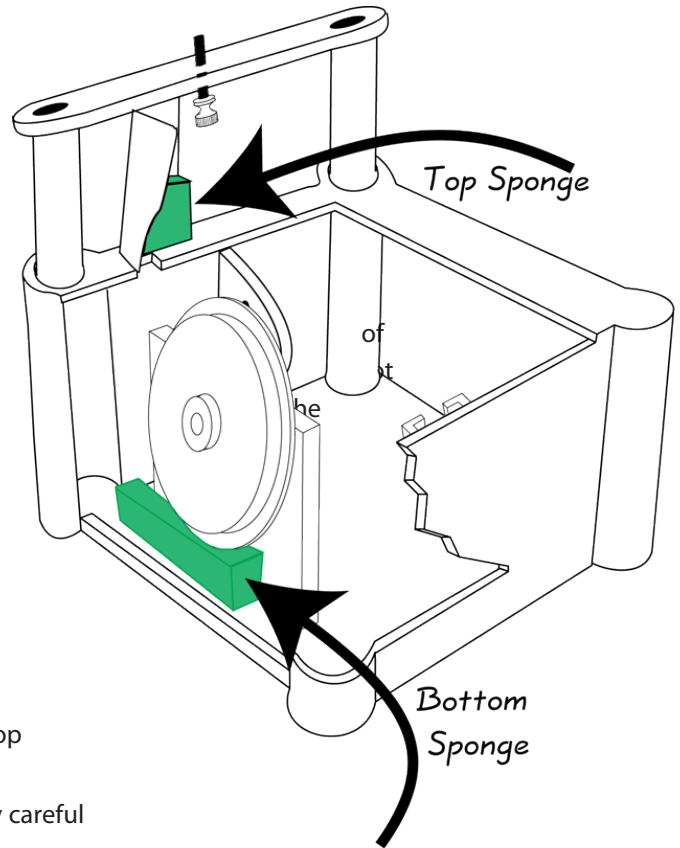

## Platform & Cover Installation

- The platform is installed with the texture side up.
- When installed, the platform surface will be flush with the top of the chassis.
- Install the platform by sliding it into place as shown. Be very careful not to nick or bend the blade while installing the platform.
- The cover, which you removed to install the blade, is reinstalled simply by sliding it down the front of the top assembly until it sits flush.

## Marking your Pattern

Since the blade carries cooling water to the glass surface, your pattern will need to be resistant to water. The best technique is to mark your pattern on the glass with a thin-line paint marker (such as the Gryphon Pattern Marking Pen). These are available from your dealer, or similar products can be obtained from artist's supply houses.

## Cutting Glass

When cutting, push your work with only a moderate pressure. Very heavy pressure will not result in faster cutting, and may bend the blade. When cutting curves, use only a light pressure and let the blade do the work. Aggressive pressure against the blade when cutting curves causes rapid wear to the back of the blade. Do not force the blade to follow a pattern, but rather guide the work through the blade. This will ensure you of the longest possible blade life. When backing out of a slot, turn motor off. Hold your thumb against the front of the blade while carefully backing the glass. Remove your thumb and start the motor.

It is normal for a blade to cut more slowly as it wears. Some materials, such as lead crystal, load the blade and cutting action slows significantly after a time. Good cutting action will be immediately restored with only a little cutting into a piece of clear window glass, silicon carbide, or a brick.

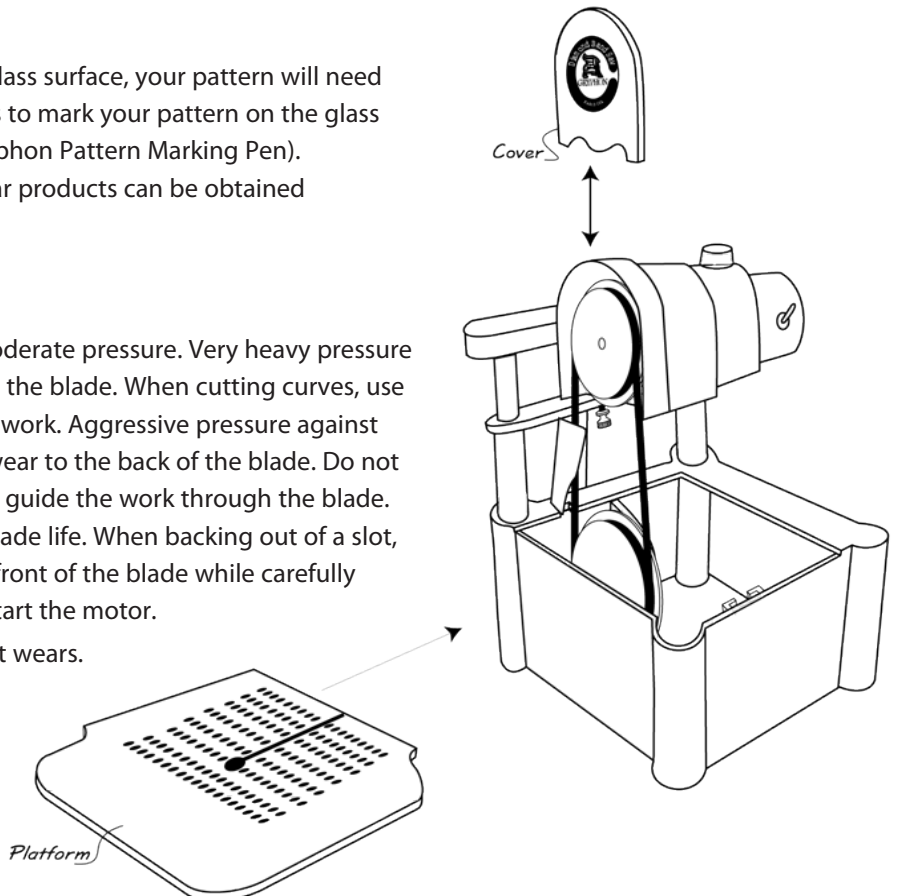

## Cutting Other Materials

The diamond blade on your band saw is useful for cutting a variety of hard materials. Stone, tile, ceramics and similar materials can be cut as easily as glass. The speed at which the saw cuts will be determined by the thickness and the hardness of the material being cut. Harder materials will wear the blade faster. Metals are too soft to be cut by a diamond blade and will gum up the blade.

## Cleaning the Saw

The glass dust that results from your cutting is carried to the bottom of the saw where it combines with the water to form a slurry. When the water becomes objectionably dirty, clean out the slurry as follows:

- Remove platform and cover.
- Remove blade.
- Remove top assembly by pulling straight up.
- Pour out dirty water outside. Do not pour into plumbing as the slurry can cause clogs.
- Use a paper towel to remove heavy slurry if required.
- Rinse out bottom assembly with a garden hose if desired.
- Do not use solvents to clean any part of the saw. Soapy water is all that is required.
- If you remove the guide holder, clean it thoroughly before replacing to ensure that it fits flush.

## Replacing Lower Wheel Adjustment Screw

If it should ever become necessary to replace the Lower adjustment screw (used for adjusting the tilt on the lower wheel), proceed as follows:

- (1) Remove old lower adjustment screw and both nuts (the rear nut is glued to the knob, and the easiest way to remove it is by cutting it off with a sharp knife).
- (2) Pass the new replacement lower adjustment screw through hole in plastic arm.
- (3) Twist two nuts halfway onto lower adjustment screw.
- (4) Screw the lower adjustment screw into hole in lower shaft assembly.
- (5) Twist nut nearest the plastic arm so that it almost touches plastic arm, but still allows knob to turn.
- (6) Install the blade and rotate the upper wheel by hand while turning lower adjustment screw in or out until the blade runs near the shoulder at the back of the lower wheel.
- (7) Turn saw on and twist lower adjustment screw until blade runs quiet and almost touches shoulder of lower wheel.
- (8) Tighten both locking nuts.

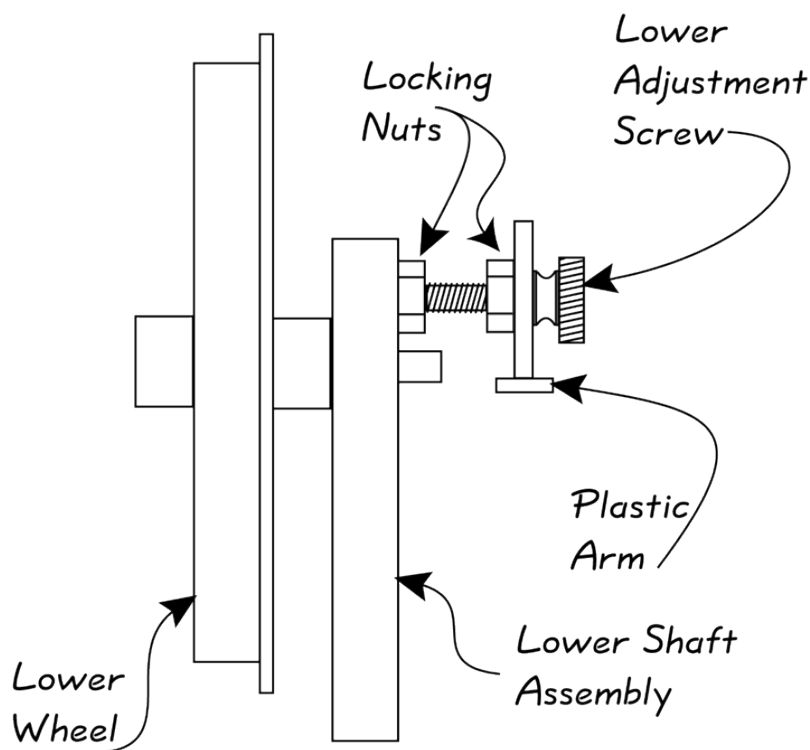



## Replacing Lower Wheel Bushing

If it should ever become necessary to replace the lower wheel bushing, proceed as follows:

- (1) Remove the lower wheel by first removing the stainless steel collar at the front of the wheel shaft, then pull the lower wheel and all the washers and O-rings off of the shaft.
- (2) Wipe the shaft clean and, if necessary, clean up the shaft with steel wool. Lubricate the shaft thinly with a petroleum jelly.
- (3) Pull the old bushings out of the lower wheel with pliers.

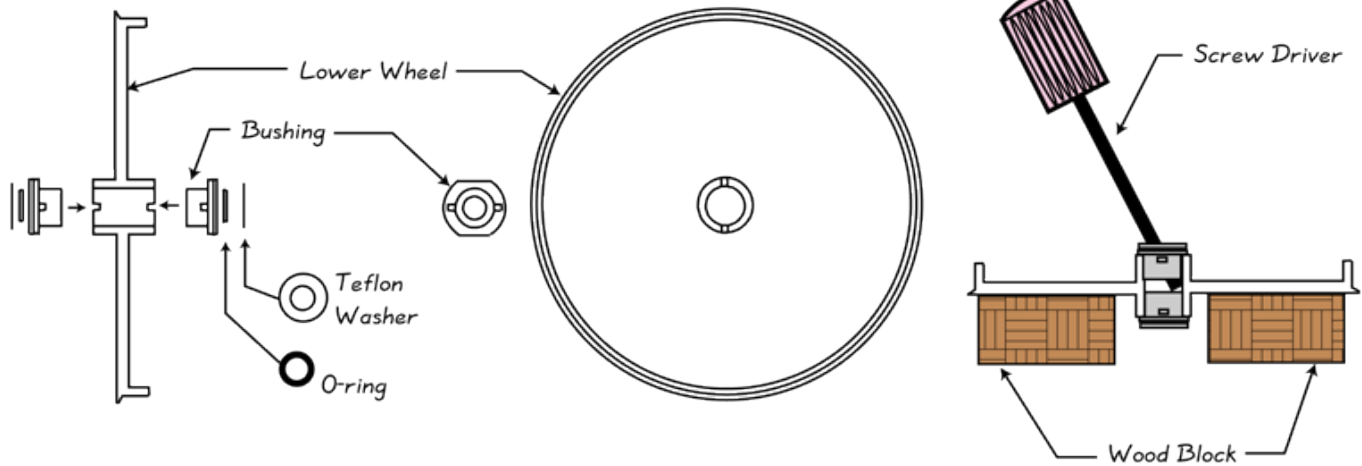

- (4) Push the new bushings into the lower wheel so that the bushing ears slip into the notches in the wheel hub. Put the assembly on the floor and step on it to firmly press the bushings into position.
- (5) Push new O-rings into the recesses in each bushing.
- (6) Place on shaft:
  - (a) lower wheel (be sure that the front O-ring stays in the recess)
  - (b) collar

Push the above group of parts tightly against the lower shaft assembly. Tighten the set-screw.

## Replacement Parts

Genuine Gryphon Diamond blades and blade guides are available through your dealer. Replacement sponges are available in most grocery stores. For other parts or warranty service, contact the factory in Sylmar, California.